

Name: _____ Date: _____

Triangle Congruence

Five Ways to Prove Triangles Are Congruent

_____	_____	_____	_____	_____
-------	-------	-------	-------	-------

What DOESN'T WORK?

Four Markings YOU can add if they aren't already marked:

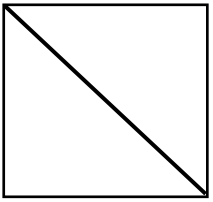
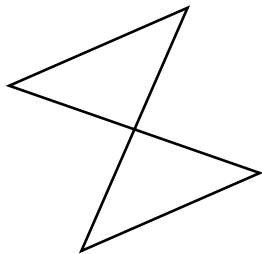
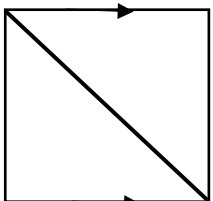
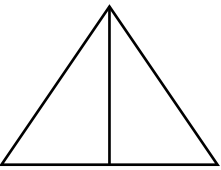
<p>If they share a side, we call it _____.</p> 	<p>If you see _____, you can mark them.</p> 	<p>Look for _____.</p> 	<p>If two triangles make up an <u>isosceles triangle</u> then mark _____ and _____.</p> 
---	--	--	---

Name the postulate or theorem you would use to prove the two triangles congruent. If there is not enough information, state NONE.

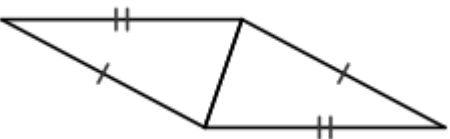
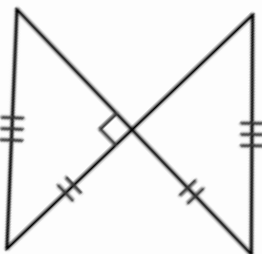
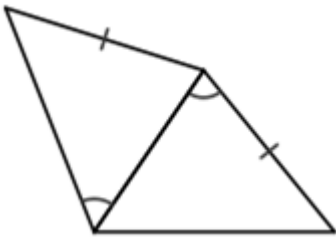
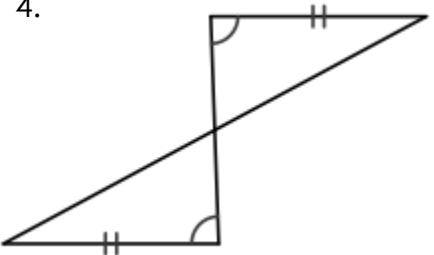
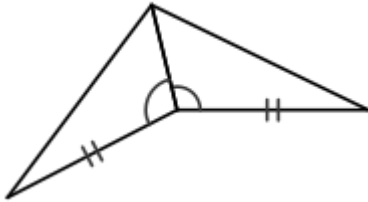
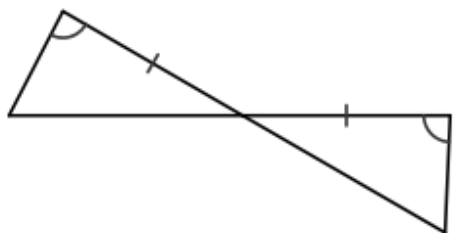
<p>1.</p> 	<p>2.</p> 	<p>3.</p> 
<p>4.</p> 	<p>5.</p> 	<p>6.</p> 

Name the postulate or theorem you would use to prove $\triangle ABC \cong \triangle ZXY$ given the following information. If there is not enough information, state NONE.

7. $\angle B \cong \angle Y$
 $\angle A \cong \angle Z$
 $\overline{BC} \cong \overline{YX}$

8. $\angle C \cong \angle X$
 $\angle A \cong \angle Z$
 $\overline{CA} \cong \overline{XZ}$

9. $\overline{AC} \cong \overline{ZX}$
 $\angle B \cong \angle Y$
 $\overline{BC} \cong \overline{YX}$

10. $\overline{ZX} \cong \overline{AC}$
 $\overline{XY} \cong \overline{CB}$
 $\angle X \cong \angle C$

11. $\overline{AB} \cong \overline{ZY}$
 $\overline{AC} \cong \overline{ZX}$
 $\overline{CB} \cong \overline{XY}$

12. $m\angle C = m\angle X = 90$
 $\overline{AB} \cong \overline{ZY}$
 $\overline{CB} \cong \overline{XY}$

State what additional information is required to know that the triangles are congruent for the reason given.

13. $\overline{JI} \cong \overline{JK}$
 SSS

14. $\overline{UV} \cong \overline{VC}$
 SAS

15. $\angle X \cong \angle J$
 ASA

16. $\overline{NR} \cong \overline{LP}$
 AAS

17. $\overline{CI} \cong \overline{JI}$
 HL

18. $\overline{JK} \cong \overline{IR}$
 SAS

19. $\triangle ABC \cong \triangle KLM$, $\angle B = 40$, $\angle M = 60$, $\angle A = (2x + 10)$. Find the value of x and $m\angle K$.

20. $\triangle ABC \cong \triangle DEF$, $AB = 2x + 10$, $BC = 12 - 2y$, $DE = 6x - 2$, $EF = 3y + 2$, $AC = 5y$. Find the values of x , y and AC .